

30-1

### Features

Features	Code
Brake Caliper	D
Mounting to the machine parallel to the brake disc	V
Frame size 020	020
Spring activated	F
Manually released	K
Manual adjustment to counter friction block wear	M
Pressure spring 510	510
Pull cable installation mounted right or left available	R L
Thickness of brake disc 12,5 mm	12

### Example for ordering

Brake Caliper DV 020 FKM, pressure spring 510, pull cable installation mounted right, thickness of brake disc 12,5 mm:

DV 020 FKM - 510 R - 12

### Technical Data

Brake Caliper DV 020 FKM with pressure spring 510	
Brake disc diameter [mm]	Braking torque [Nm]
200	160
250	210
300	270
355	330
430	410
520	510
Clamping force	2750 N
Weight	4,4 kg

The braking torques shown in the table are based on a theoretical friction coefficient of 0,4.

### Accessories

The Brake Caliper can be delivered fully assembled with Pull Cable and Hand Brake Lever. Please indicate the required cable length.

For further information regarding Pull Cables and Hand Brake Lever see page 71.

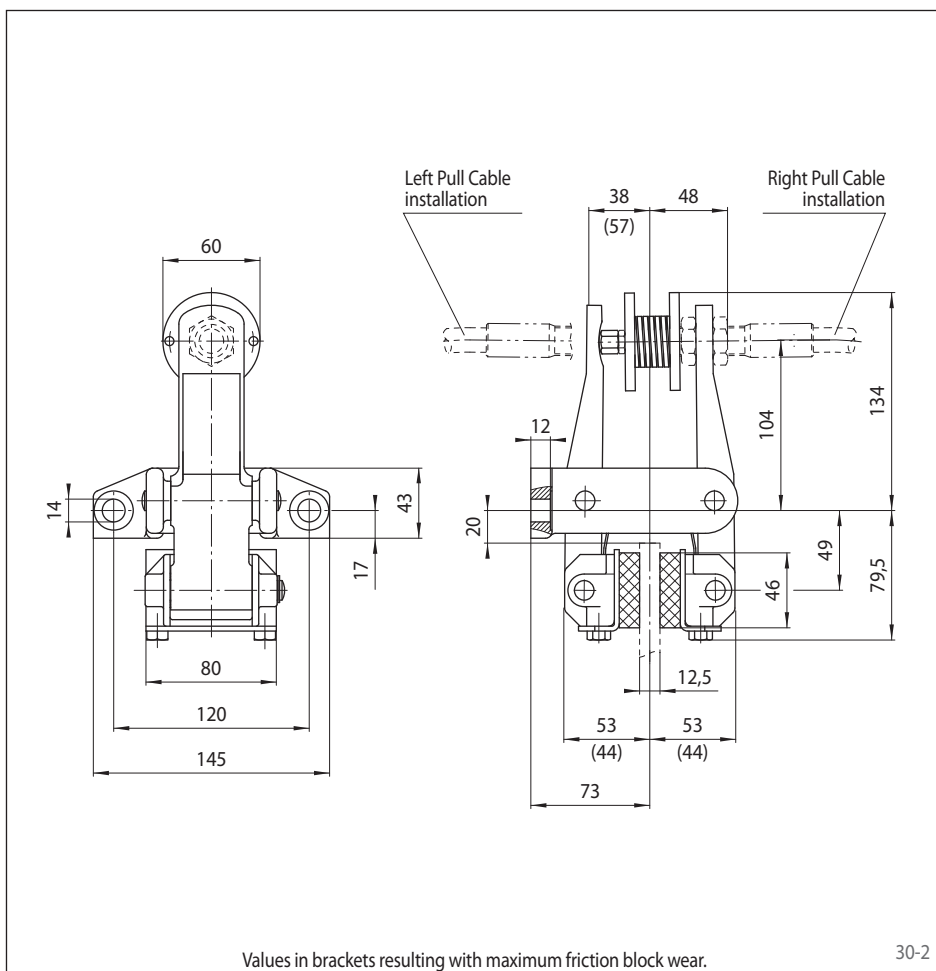

30-2